



Estd:2008

METHODIST COLLEGE OF ENGINEERING AND TECHNOLOGY

(Affiliated to Osmania University & approved by AICTE, New Delhi)



LABORATORY MANUAL

MECHANICS OF MATERIALS LABORATORY

BE IV Semester (Autonomous): 2022-23

NAME: _____

ROLL NO: _____

BRANCH: _____

SEM: _____

DEPARTMENT OF CIVIL ENGINEERING

Empower youth- Architects of Future



Estd:2008

METHODIST COLLEGE OF ENGINEERING AND TECHNOLOGY

(Affiliated to Osmania University & approved by AICTE, New Delhi)

VISION OF INSTITUTION

To produce ethical, socially conscious and innovative professionals who would contribute to sustainable technological development of the society.

MISSION OF INSTITUTION

To impart quality engineering education with latest technological developments and interdisciplinary skills to make students succeed in professional practice.

To encourage research culture among faculty and students by establishing state of art laboratories and exposing them to modern industrial and organizational practices.

To inculcate humane qualities like environmental consciousness, leadership, social values, professional ethics and engage in independent and lifelong learning for sustainable contribution to the society.



Estd:2008

METHODIST COLLEGE OF ENGINEERING AND TECHNOLOGY

(Affiliated to Osmania University & approved by AICTE, New Delhi)

DEPARTMENT OF CIVIL ENGINEERING

LABORATORY MANUAL

MECHANICS OF MATERIALS LABORATORY

Prepared

By

Mr.P.Srikanth

Assistant Professor.



Estd:2008

METHODIST COLLEGE OF ENGINEERING AND TECHNOLOGY

(Affiliated to Osmania University & approved by AICTE, New Delhi)

DEPARTMENT OF CIVIL ENGINEERING

VISION

To evolve into a centre of excellence for imparting holistic civil engineering education contributing towards sustainable development of the society.

MISSION

- To impart quality civil engineering education blended with contemporary and interdisciplinary skills.
- To provide enhanced learning facilities and professional collaborations to impart a culture of continuous learning.
- To involve in trainings and activities on communication skills, teamwork, professional ethics, environmental protection and sustainable development.



Estd:2008

METHODIST COLLEGE OF ENGINEERING AND TECHNOLOGY

(Affiliated to Osmania University & approved by AICTE, New Delhi)

DEPARTMENT OF CIVIL ENGINEERING

PROGRAM EDUCATIONAL OBJECTIVES

The Graduates of the programme shall be able to:

PEO 1: Engage in planning, analysis, design, construction, operation and maintenance of built environment.

PEO 2: Apply the knowledge of civil engineering to pursue research or to engage in professional practice.

PEO 3: Work effectively as individuals and as team members in multidisciplinary projects with organizational and communication skills.

PEO 4: Demonstrate the spirit of lifelong learning and career enhancement aligned to professional and societal needs.



Estd:2008

METHODIST COLLEGE OF ENGINEERING AND TECHNOLOGY

(Affiliated to Osmania University & approved by AICTE, New Delhi)

DEPARTMENT OF CIVIL ENGINEERING

PROGRAM OUTCOMES

Engineering Graduates will be able to:

- PO1. Engineering knowledge:** Apply the knowledge of mathematics, science, engineering fundamentals, and civil engineering specialization to the solution of complex civil engineering problems.
- PO2. Problem analysis:** Identify, formulate, review research literature, and analyze complex civil engineering problems reaching substantiated conclusions using first principles of mathematics, natural sciences, and engineering sciences.
- PO3. Design/development of solutions:** Design solutions for complex civil engineering problems and design system components or processes that meet the specified needs with appropriate consideration for the public health and safety, and the cultural, societal, and environmental considerations.
- PO4. Conduct investigations of complex problems:** Use research-based knowledge and research methods including design of experiments, analysis and interpretation of data, and synthesis of the information to provide valid conclusions.
- PO5. Modern tool usage:** Create, select, and apply appropriate techniques, resources, and modern engineering and IT tools including prediction and modeling to complex civil engineering activities with an understanding of the limitations.
- PO6. The engineer and society:** Apply reasoning informed by the contextual knowledge to assess societal, health, safety, legal and cultural issues and the consequent responsibilities relevant to the professional civil engineering practice.
- PO7. Environment and sustainability:** Understand the impact of the professional civil engineering solutions in societal and environmental contexts, and demonstrate the knowledge of, and need for sustainable development.
- PO8. Ethics:** Apply ethical principles and commit to professional ethics and responsibilities and norms of the civil engineering practice.

PO9. Individual and team work: Function effectively as an individual, and as a member or leader in diverse teams, and in multidisciplinary settings.

PO10. Communication: Communicate effectively on complex engineering activities with the engineering community and with society at large, such as, being able to comprehend and write effective reports and design documentation, make effective presentations, and give and receive clear instructions.

PO11. Project management and finance: Demonstrate knowledge and understanding of the engineering and management principles and apply these to one's own work, as a member and leader in a team, to manage projects and in multidisciplinary environments.

PO12. Life-long learning: Recognize the need for and have the preparation and ability to engage in independent and life-long learning in the broadest context of technological change.

PROGRAM SPECIFIC OUTCOMES

Civil Engineering Graduates will be able to:

PSO 1. Investigate properties of traditional and latest construction materials using standard testing methods.

PSO 2. Use AutoCAD, STAAD Pro, ETABS, Revit Architecture and ANSYS software for computer aided structural analysis and design.

PSO 3. Describe the principles of sustainable development and green buildings for environmental preservation.



METHODIST COLLEGE OF ENGINEERING AND TECHNOLOGY

(Affiliated to Osmania University & approved by AICTE, New Delhi)

Laboratory Code of Conduct

1. Students should report to the concerned labs as per the time table schedule.
2. Students who turn up late to the labs will in no case be permitted to perform the experiment scheduled for the day.
3. Students should bring a note book of about 100 pages and should enter the readings/observations into the note book while performing the experiment.
4. After completion of the experiment, certification of the concerned staff in-charge in the observation book is necessary.
5. Staff member in-charge shall award 40 marks for each experiment based on continuous evaluation and will be entered in the continuous internal evaluation sheet.
6. The record of observations along with the detailed experimental procedure of the experiment performed in the immediate last session should be submitted and certified by the staff member in-charge.
7. Not more than three students in a group are permitted to perform the experiment on a set-up for equipment-based labs. Only one student is permitted per computer system for computer-based labs.
8. The group-wise division made in the beginning should be adhered to, and no student is allowed to mix up with different groups later.
9. The components required pertaining to the experiment should be collected from the stores in-charge, only after duly filling in the requisition form/log register.
10. When the experiment is completed, students should disconnect the setup made by them, and should return all the components/instruments taken for the purpose.
11. Any damage of the equipment or burn-out of components will be viewed seriously by either charging penalty or dismissing the total group of students from the lab for the semester/year.
12. Students should be present in the labs for the total scheduled duration.
13. Students are required to prepare thoroughly to perform the experiment before coming to Laboratory.
14. Procedure sheets/data sheets provided to the students, if any, should be maintained neatly and returned after the completion of the experiment.



METHODIST COLLEGE OF ENGINEERING AND TECHNOLOGY

Estd:2008

(Affiliated to Osmania University & approved by AICTE, New Delhi)

Name of the laboratory course: Mechanics of Materials Laboratory

Course code: 2PC453CE

DOs and DON'Ts

DOs:

1. Students are expected to prepare thoroughly to perform the experiment before coming to laboratory.
2. Always perform the experiment precisely as directed by the faculty.
3. Don't forget to bring observation notes, calculator and other pencil accessories before coming to laboratory
4. Record should be updated from time to time and the previous experiment must be signed by the faculty in-charge before attending the lab.
5. After completion of the experiment, signature of the faculty in-charge in the observation book is necessary.
6. The components required pertaining to the experiment should be collected from lab technician after duly filling in the requisition form.
7. Handover all the accessories /material / instruments to the lab technician before leaving the laboratory
8. Wear shoes and apron while performing the experiment
9. Keep silence in the laboratory

DON'Ts

1. Don't use mobile phones during lab hours
2. Don't use instruments without permission of the lab incharge
3. Don't be late for the lab session



Estd:2008

METHODIST COLLEGE OF ENGINEERING AND TECHNOLOGY

(Affiliated to Osmania University & approved by AICTE, New Delhi)

Name of the laboratory course: Mechanics of Materials Lab

CIE: 40 marks

Course code: 2PC453CE

SEE: 60 marks

Credits:1

List of Experiments

1. Uni- axial tension test on a specimen of ductile material
2. Stress – Strain characteristics of a ductile material
3. Brinell`s hardness test
4. Izod impact test
5. Compression test on open coiled helical spring
6. Torsion test on a specimen of ductile material
7. Bending test on simply supported beam of Timber
8. Bending test on Simply supported beam of Steel
9. Bending test on Cantilever beam of Aluminium
10. Bending test on Fixed beam of copper

Additional experiments

11. Tension test on closed coiled helical spring
12. Charpy impact test



Estd:2008

METHODIST COLLEGE OF ENGINEERING AND TECHNOLOGY

(Affiliated to Osmania University & approved by AICTE, New Delhi)

Name of the laboratory course: Mechanics of Materials Lab

Course code: 2PC453CE

Course Outcomes

After completing this course, the student will be able to:

| CO No. | Course Outcome |
|---------------|--|
| CO1 | Appraise the behaviour of a ductile material under direct tension test, in addition to gaining knowledge on elastic properties of the material |
| CO2 | Identify the hardness of various metals like brass, copper, aluminium etc |
| CO3 | Assess and understand the flexural properties of beams (simply supported, cantilever and fixed) of different materials like wood, steel, copper, aluminium etc |
| CO4 | Interpret the application of tension and compression springs in practice to understand the properties like stiffness, capacity, shear modulus etc. of the springs |
| CO5 | Understanding the impact properties of the materials and also energy absorption |



Estd:2008

METHODIST COLLEGE OF ENGINEERING AND TECHNOLOGY

(Affiliated to Osmania University & approved by AICTE, New Delhi)

Name of the laboratory course: Mechanics of Materials Lab

Course code: 2PC453CE

Experiments mapping to COs & POs

| S. No | Name of the Experiment | COs | POs |
|-------|---|----------|----------------|
| 1 | Uni- axial tension test on a specimen of ductile material | CO1 | PO1, PO5, PSO1 |
| 2 | Stress – Strain characteristics of a ductile material | CO1 | PO2, PO5, PSO1 |
| 3 | Brinell`s hardness test | CO2 | PO1, PO5, PSO1 |
| 4 | Izod impact test | CO5 | PO1, PO5, PSO1 |
| 5 | Compression test on open coiled helical spring | CO4 | PO1, PO5, PSO1 |
| 6 | Torsion test on a specimen of ductile material | CO1 | PO1, PO5, PSO1 |
| 7 | Bending test on simply supported beam of Timber | CO3 | PO1, PO5, PSO1 |
| 8 | Bending test on Simply supported beam of Steel | CO3 | PO1, PO5, PSO1 |
| 9 | Bending test on Cantilever beam of Aluminium | CO3 | PO1, PO5, PSO1 |
| 10 | Bending test on Fixed beam of copper | CO3 | PO1, PO5, PSO1 |
| 11 | Tension test on closed coiled helical spring | CO1, CO4 | PO1, PO5, PSO1 |
| 12 | Charpy impact test | CO5 | PO1, PO5, PSO1 |

EXPERIMENT 1

Uni- axial tension test on a specimen of ductile material

AIM: To conduct tension test on a mild steel bar to find its

- (i) Ultimate stress
- (ii) Breaking stress
- (iii) Percentage elongation and
- (iv) Modulus of elasticity of the material.

EQUIPMENT:

Tension testing machine, vernier calipers, Extensometer and Inside calipers.

PRINCIPLE / THEORY:

Young's modulus: The ratio of stress to strain within the proportionality limit over a gauge length

Ultimate stress (kg/cm²) = Ultimate load / Initial cross sectional area =

Breaking stress (kg/cm²) = Breaking load / Initial cross sectional area =

Elongation (%) = (Change in Length up to failure / Original length) × 100

Reduction in area of cross section (%) = $\{(A - A_1) / A\} \times 100 =$

A – Initial area of cross section = $(\pi / 4) d^2$

A₁ – Area of cross section at the broken section = $(\pi / 4) d_1^2$

d = Initial diameter of the bar,

d₁ = Reduced diameter of the bar

DESCRIPTION:

In the Tension testing machine, the load is applied through the use of screw-gear mechanism. The machine consists of base and vertical channels, which support the load-measuring unit. The base houses the drive unit. The drive is affected by an electric motor whose stroke is transmitted through set of pulleys to the spindle. Load can also be applied

manually by rotating loading wheel. When pull is applied to specimen, the pendulum gets deflected from its vertical position in proportion to pull applied and the tensile force is indicated on the dial by the drag pointer. To record the curve of the test, the machine is equipped with autograph recorder. To prevent sudden fall of the pendulum rod on rupture of the specimen, the damping unit is provided which ensures that the pendulum rod slowly goes back to its vertical position. When the pendulum rod falls back, the drag pointer rod remains in its position to indicate maximum strength developed during the strength.

The machine has three loading ranges, 1 tonne, 2.5 tonnes and 5 tonnes. The following calibrated discs are to be attached to get the required load ranges.

| | | |
|-------------------------|---|--------------|
| Disc A | → | 0-1.0 tonne |
| Discs A + B + C | → | 0-2.5 tonnes |
| Discs A + B + C + D + E | → | 0-5.0 tonnes |

The automatic graph recorder consists of an aluminum drum on which a graph paper is wound. Curve is drawn with a pen connected to pendulum rod through rack.

On drum, the tensile force is recorded on horizontal axis and the elongation is recorded in the direction of vertical axis. If the graph paper is taken off and turned by 90 degrees, the curves are obtained in the usual representation i.e., load on y-axis and extension on x-axis.

PROCEDURE:

- (1) Considering the breaking strength of the test specimen select appropriate loading range. Place suitable weight discs on the pendulum of the machine.
- (2) Depending on the dimensions of the test specimen, appropriate gripping jaws should be installed in grip housing.
- (3) Measure the diameter 'd' of the specimen and fix the specimen in between the grips. Measure the length between the grips 'L'.
- (4) Fix the extensometer to the specimen and note down the gauge length. Also note the initial reading on the meter scale fixed to the frame 'L₁'.
- (5) Set Loading dial pointer and extensometer pointer to zero.

- (6) Note the elongation reading in the extensometer for each suitable increment of load. The load increases gradually and reaches a maximum value called ultimate load. Note the ultimate load and at this stage, remove the extensometer.
- (7) Continue the loading till the specimen breaks and note down the breaking load.
- (8) Note the final reading on the meter scale 'L₂'.
- (9) Measure the reduced diameter of the specimen 'd₁'.

OBSERVATIONS:

FROM VERNIER CALLIPERS

Least count of vernier calipers = 0.002 cm

| S. No. | Main scale reading M.S.R (cm) | Vernier Scale coincidence V.S.C (div) | Diameter = M.S.R + L.C × V.S.C (cm) |
|--------|----------------------------------|---|---|
| 1 | | | |
| 2 | | | |
| 3 | | | |

Average diameter 'd' = cm

Length of the specimen between grips 'L' = cm

Initial reading on the main scale 'L₁' = cm

Final reading on the main scale 'L₂' = cm

Final diameter 'd₁' = cm

FROM EXTENSOMETER

Least Count of Extensometer = cm

| S. No. | Load Applied (kg) | Extensometer reading | | Stress in (kg/cm ²) | Strain e= $\delta l / l$ |
|--------|-------------------|----------------------|-------|---------------------------------|--------------------------|
| | | (div) | (cm) | | |
| 1 | | | | | |
| 2 | | | | | |
| 3 | | | | | |
| 4 | | | | | |
| 5 | | | | | |
| 6 | | | | | |
| 7 | | | | | |
| 8 | | | | | |
| 9 | | | | | |
| 10 | | | | | |
| 11 | | | | | |
| 12 | | | | | |

Ultimate Load 'P_u' = kg

Breaking Load 'P_b' = kg

CALCULATIONS:

A - Initial area of cross section = $(\pi / 4) d^2$ = cm²

A₁ - Area of c/s at the broken section = $(\pi / 4) d_1^2$ = cm²

Ultimate stress = P_u / A = kg/cm²

Breaking stress = P_b / A = kg/cm²

Percentage elongation = $\{(L_2 - L_1) / L\} \times 100 =$

$$\text{Percentage reduction in area} = \{(A - A_1) / A\} \times 100 =$$

Specimen Calculation:

$$\text{Stress} = \quad \text{kg / cm}^2 .$$

$$\text{Strain} =$$

$$\text{Young's Modulus 'E'} = \frac{\text{Stress}}{\text{Strain}} = \quad \text{kg/cm}^2$$

RESULT:

1..Young's Modulus 'E' of given material specimen from graph is
kg/cm²

2. Ultimate stress = kg/cm²

3. Breaking Stress = kg/cm²

4. Elongation (%) =

5. Reduction in Area (%) =

EXPERIMENT 2

BRINELL'S Hardness Test

AIM: To determine the hardness number of brass and copper specimens

EQUIPMENT:

Hardness testing machine, Indentor, Allen key and Microscope.

THEORY / PRINCIPLE:

Hardness, in the case of Rockwell test, is based directly on the depth of plastic deformation under the major load. It depends on the load and type of indentor used. The same material will give different values as measured in B or C scales. This is not the case with Brinell hardness test.

Brinell Hardness Number (referred to as B.H.N.) = P/A

Where P = Total load applied in Kg

A = Surface area of the indentation measured in mm² units

$$= \frac{\pi D \{D - \sqrt{D^2 - d^2}\}}{2}$$

D = diameter of indenter, d = diameter of indentation.

Hard steel balls of diameter ranging from 1mm to 10mm are used as indenters. For the given material, the same B.H.N value will be obtained irrespective of the total load and ball diameter used. Usual diameters of Balls used are of 2.5mm, 5mm, and 10mm. The load to be applied depends on the material type and the diameter of indenter used. The values of 'P/D²' for different materials are given below:

| S. No. | Approximate B.H.N | P/D ² Ratio | Representative Material |
|--------|-------------------|------------------------|-------------------------|
| 1 | Above 160 | 30 | Steel, cast iron |
| 2 | 160 to 60 | 10 | Copper alloys |
| 3 | 60 to 20 | 5 | Copper, Aluminum |
| 4 | Less than 20 | 1 | Lead, tin, their alloys |

PROCEDURE:

1. Considering the material of the specimen, decide in advance the diameter of the indenter to be used and total load to be applied.
2. Clamp the indenter to the machine.
3. Move the load selector disc to the load required.
4. Place the specimen on the platform and rotate the wheel at the base until specimen on the platform touches the indenter so that large and small pointer on the dial comes to set position.
5. Apply the major load by moving the loading lever slowly in the clockwise direction. Wait for a few seconds after pointer comes to rest indicating full application of the load and then reverse the lever slowly to remove the load.
6. Rotate the wheel at the base of the stem and then remove the specimen.
7. Mark the indentation in ink or with chalk to identify it.
8. Using the Brinell Microscope, measure the diameter 'd' of the indentation in mm.
9. Calculate the value of B.H.N.

OBSERVATIONS:

| S. No. | Specimen | Load applied P (kg) | Diameter of the indenter D (mm) | Diameter of the indentation d (mm) | Surface area of the indentation (mm ²) $A = \frac{\pi D \left\{ D - \sqrt{D^2 - d^2} \right\}}{2}$ | B.H.N = P/A |
|--------|----------|---------------------|---------------------------------|------------------------------------|---|-------------|
| | | | | | | |
| | | | | | | |
| | | | | | | |
| | | | | | | |
| | | | | | | |

RESULT:

1. BHN of specimen 1 =
2. BHN of specimen 2 =

INFERENCE:

EXPERIMENT 3

IZOD Impact Test

AIM: To determine the toughness of the given material using Izod impact test

EQUIPMENT:

Impact testing machine, Allen key and setting gauge.

PRINCIPLE / THEORY:

Toughness of the material of the specimen is the property by virtue of which it is capable of absorbing energy during plastic deformation. High strength and large ductility increase toughness.

The test essentially consists of holding the specimen at the position with proper grip, raising the pendulum through a specified angle, realizing it to strike the specimen to cause fracture and measuring the energy lost in breaking the specimen. The energy lost is directly read on the dial.

Mass of pendulum = 21.79 kg

Angle of drop of pendulum = $85^{\circ} 21'$

Effective length of pendulum = 0.825 m

Energy at impact = $21.79 \times 9.81 \times 0.825 \times (1 - \cos 85^{\circ} 25') = 164 \text{ J}$

The energy scale is graduated to read directly the energy lost at impact.

DESCRIPTION OF THE MACHINE:

The machine combines the facility for performing different standard impact tests on the specimens of metals such as steel, copper and alloys. The standard tests are as follows:

The machine has the following ranges:

(a) 300 J for Charpy Impact Tension test

(b) 164 J for Izod impact Test

The machine has a pendulum of specified weight for each test having an effective length of 0.825 m. for each of the test, the appropriate grips of striking tool have to be used.

PROCEDURE:

A. Specimen for Izod Impact Test:

Izod specimen made out of 10mm round bar has v-notch of depth 2 mm with included angle of 45 at the section where it is required to fracture by impact. Single notch specimens have an overall length of 75mm with a V-notch cut at a distance of 28mm from one end. Triple notch specimens have an overall length of 130 mm with V-Notch being cut at a distance of 28mm from one end on face, at 56mm from the end on a perpendicular face and 84 mm on the face opposite to the first face

B. Test Procedure:

1. The proper striker is first securely fixed to the bottom of the hammer and the clamping device for Izod specimen is fixed to the base.
2. The latching tube for Izod test is also fixed to the stand so as to enable holding of the pendulum correctly in the initial position for the test.
3. The 3" pipe supplied is then placed in the rectangular hole in the side guard to prevent accidental fall of the pendulum.
4. The Izod specimen is firmly fixed in the clamping device with the notch facing the striker.
5. The protecting pipe is removed, hammer is released and reading of pointer is noted to yield the value of energy lost in breaking the specimen.

RESULT:

1. Energy lost during impact in joules =

2. Impact Strength $I = \frac{K}{A}$ in $\frac{J}{mm^2}$ =

Where, K= Energy lost by the hammer.

A= Area of cross section at the notch.

EXPERIMENT 4

CHARPY IMPACT TEST

AIM: To find toughness of the given specimens by conducting Charpy impact test.

EQUIPMENT:

Impact testing machine and Allen key.

PRINCIPLE / THEORY:

Toughness of the material of the specimen is the property by virtue of which it is capable of absorbing energy during plastic deformation. High strength and large ductility increase toughness.

The test essentially consists of holding the specimen at the position with proper grip, raising the pendulum through a specified angle, realizing it to strike the specimen to cause fracture and measuring the energy lost in breaking the specimen. The energy lost is directly read on the dial.

| | | |
|------------------------------|---|--|
| Mass of pendulum | = | 20.932 kgs |
| Angle of drop of pendulum | = | 140° 18' |
| Effective length of pendulum | = | 825 mm |
| Energy at impact | = | 20.932 x 9.81 x 0.825 x (1-cos 140° 18') |
| | = | 299.75 = 300 J |

The energy scale is graduated to read directly the energy lost at impact.

DESCRIPTION OF THE MACHINE:

The machine combines the facility for performing different standard impact tests on the specimens of metals such as steel, copper and alloys. The standard tests are as follows:

The machine has the following ranges:

- (a) 300 J for Charpy Impact Tension test
- (b) 164 J for Izod impact Test

The machine has a pendulum of specified weight for each test having an effective length of 0.825 m. for each of the test, the appropriate grips of striking tool have to be used.

PROCEDURE:

A. Specimen for Charpy Impact Test:

Charpy specimen shall be prepared as per the IS 1499 – 1959. The length of the specimen width and height shall be has given below

| | | |
|--------|---|---------------------|
| Length | = | 55 mm \pm 0.6mm |
| Width | = | 10 mm \pm 0.11 mm |
| Height | = | 10 mm \pm 0.11 mm |

The specimen of above specified dimension shall be cut at the center of supports such that the groove shall have a depth of 5 mm, width of 2mm with a root radius of 1 mm. The groove shall be perpendicular to the longitudinal axis.

B. Test Procedure:

1. The Charpy striker is first securely fixed to the bottom of the hammer and the clamping device for Charpy test is to the fixed to the bottom base in order to hold the specimen in position.
2. The latch tube Charpy test is then fixed at the top and the hammer is brought to the level of latch tube and locked to the latch tube.
3. The specimen prepared as per the specifications is then fixed in position as shown in figure at the base and the lock of the hammer shall be released from the latch tube by operating the lock lever attached to the latch tube. Precaution must be taken that the pointer on the calibration should be at 300 J reading, before releasing the hammer.
4. The reading of the pointer after breaking the specimen is noted which indicates the energy required to fracture the specimen.

RESULT:

3. Energy lost during impact in joules =

4. Impact Strength $I = \frac{K}{A}$ in $\frac{J}{mm^2}$ =

Where, K= Energy lost by the hammer.

A= Area of cross section at the notch.

INFERENCE:

EXPERIMENT 5

COMPRESSION TEST ON OPEN COILED HELICAL SPRING

AIM: To determine the modulus of rigidity (G) of the material of the given spring.

EQUIPMENT

Spring testing machine with proving ring and Vernier calipers.

THEORY / PRINCIPLE:

The deflection of a Open coiled helical spring is given by

$$\delta = \frac{64WR^3n \sec \alpha}{d^4} \left(\frac{\cos^2 \alpha}{G} + \frac{2\sin^2 \alpha}{E} \right)$$

- Where W = load applied on the spring
R = mean radius of the coil of the spring
d = diameter of the spring wire
n = No. of turns of the spring / no. of coils
G = modulus of rigidity of the material

$$\text{Youngs Modulus } E = 2G(1 + \mu)$$

$$\text{Angle of Helix } \alpha = \tan^{-1} \left(\frac{\text{pitch}}{2\pi R} \right)$$

$$\text{pitch} = \left(\frac{l - d}{n} \right)$$

μ = Poisson ratio for Steel = 0.3

L = Length of the spring

The stiffness of the spring is defined as the force required per unit deflection.

$$K = W / \delta$$

PROCEDURE:

1. Measure the diameter of the coil and the wire with the vernier calipers.
2. Calculate the mean radius of the coil.
3. Apply the load in about 5 increments of 2.5 kg each. In the experiment the load is applied by mechanical means through the use of screw-gear mechanism and a proving ring does the load measurement.
4. Measure the deflection corresponding to each load with the help of dial gauge fixed to the frame.
5. Plot a graph between Load (on Y-axis) Vs Deflection (on X-axis) and calculate the slope of the line.
6. Calculate the modulus of rigidity 'G'.

OBSERVATIONS

Least count of proving ring = 2.5 kg

Least count of dial gauge = 0.001 cm

Compression Spring:

No. of turns of the spring =

Least count of Vernier calipers. = cm

Diameter of Coil 'D' of Compression spring

| S. No. | Main scale reading M.S.R (cm) | Vernier Scale coincidence V.S.C (div) | Diameter = M.S.R + L.C x V.S.C (cm) |
|--------|----------------------------------|---|--|
| 1 | | | |
| 2 | | | |
| 3 | | | |

Average diameter of the coil 'D' = cm

Diameter of Spring wire 'd' of Compression spring

| S. No. | Main scale reading M.S.R (cm) | Vernier Scale coincidence V.S.C (div) | Diameter = M.S.R + L.C x V.S.C (cm) |
|--------|----------------------------------|---|--|
| 1 | | | |
| 2 | | | |
| 3 | | | |

Average diameter of the spring wire 'd' = cm

| S. No. | Load applied (kg) | Dial gauge reading | |
|--------|-------------------------|--------------------|------|
| | | (div) | (cm) |
| 1 | 0 | 0 | 0 |
| 2 | 2.5 | | |
| 3 | 5.0 | | |
| 4 | 7.5 | | |
| 5 | 10.0 | | |
| 6 | 12.5 | | |

CALCULATIONS:

Mean radius of the coil $R = \frac{D_0 + D_i}{4}$

Specimen calculation:

W = kg.

δ = cm

Rigidity modulus 'G' =

Modulus of rigidity of the material 'G' from the graph =

RESULTS:

Rigidity modulus (G) of given Compression spring is: N/mm²

INFERENCE:

EXPERIMENT 6

Tension Test on Closed Coiled Helical Spring

AIM: To determine the modulus of rigidity (G) of the material of the given spring.

EQUIPMENT

Spring testing machine with proving ring and Vernier calipers.

THEORY / PRINCIPLE:

The deflection of a close coiled helical spring is given by

$$\delta = \frac{64WR^3 n}{Gd^4}$$

| | | |
|----------|---|---|
| Where, W | = | load applied on the spring |
| R | = | mean radius of the coil of the spring |
| d | = | diameter of the spring wire |
| n | = | No. of turns of the spring / no. of coils |
| G | = | modulus of rigidity of the material |

The stiffness of the spring is defined as the force required per unit deflection.

$$K = W / \delta$$

PROCEDURE:

1. Measure the diameter of the coil and the wire with the vernier calipers.
2. Calculate the mean radius of the coil.
3. Apply the load in about 5 increments of 2.5 kg each. In the experiment the load is applied by mechanical means through the use of screw-gear mechanism and a proving ring does the load measurement.
4. Measure the deflection corresponding to each load with the help of dial gauge fixed to the frame.
5. Plot a graph between Load (on Y-axis) Vs Deflection (on X-axis) and calculate the slope of the line.
6. Calculate the modulus of rigidity 'G'.

OBSERVATIONS:

Least count of proving ring = 2.5 kg

Least count of dial gauge = 0.001 cm

Compression Spring:

No. of turns of the spring =

Least count of Vernier calipers. = cm

Diameter of Coil 'D' of Compression spring

| S. No. | Main scale reading M.S.R (cm) | Vernier Scale coincidence V.S.C (div) | Diameter = M.S.R + L.C x V.S.C (cm) |
|--------|----------------------------------|---|--|
| 1 | | | |
| 2 | | | |
| 3 | | | |

Average diameter of the coil 'D' = cm

Diameter of Spring wire 'd' of Compression spring

| S. No. | Main scale reading M.S.R (cm) | Vernier Scale coincidence V.S.C (div) | Diameter = M.S.R + L.C x V.S.C (cm) |
|--------|----------------------------------|---|--|
| 1 | | | |
| 2 | | | |
| 3 | | | |

Average diameter of the spring wire 'd' = cm

| S. No. | Load applied (kg) | Dial gauge reading | |
|--------|-------------------------|--------------------|------|
| | | (div) | (cm) |
| 1 | 0 | 0 | 0 |
| 2 | 2.5 | | |
| 3 | 5.0 | | |
| 4 | 7.5 | | |
| 5 | 10.0 | | |
| 6 | 12.5 | | |

CALCULATIONS

Mean radius of the coil R = (D – d) / 2

Specimen calculation:

W = kg.

δ = cm

Rigidity modulus 'G' =
$$\frac{64WR^3 n}{\delta d^4}$$

Modulus of rigidity of the material 'G' from the graph =
$$\frac{w}{\delta} \left(\frac{64R^3 n}{d^4} \right)$$

RESULTS:

Rigidity modulus (G)(N/mm²) of Compression spring =

EXPERIMENT 7

Torsion Test

AIM : To determine the modulus of rigidity of the material of the given specimen by conducting torsion test.

EQUIPMENT:

Torsion testing Machine, Vernier calipers, Scale and Inside calipers.

PRINCIPLE:

When a straight circular bar of a given material is subjected to a torque 'T', the angle of twist 'θ' in radians over a length 'L' of the bar is given by

$$\theta = \frac{T.L}{G.J}$$

Where, J = Polar moment of inertia = $\pi d^4 / 32$.

d = Diameter of the given specimen

G = Modulus of rigidity

DESCRIPTION OF THE MACHINE:

The torsion-testing machine consists of two sturdy stands on which the base frame is firmly fixed. To the left end of the machine the driving unit jaw is fixed on the base frame and to the right end of the machine the stationary jaw and the pendulum dynamometer system is fixed. The torque applied by motor or hand wheel through the driving chuck, to the specimen, is transferred to the pendulum compensates this torque. This amount of swing is sensed by a rack and mirror system and is directly indicated on a big size dial which is also mounted on the trolley bracket. A dummy pointer on the dial helps to store the torque reading when the specimen breaks or the test ends as the case may be. A recorder attached to the dial records the torque-twist diagram. A dash pot connected to the trolley bracket serves for slow release of the load when the specimen breaks.

PROCEDURE:

1. Considering the strength of the specimen, place the pendulum weight and adjust corresponding range on the dial with adjusting knob.
2. Select suitable jaw sets for the specimen. Insert them into driving chuck and fix the specimen at one end.
3. Depending on the length of the specimen, move the trolley bracket towards the driving chuck and grip the other end of the specimen.
4. Measure the length between the chucks 'L' and the diameter of the specimen 'd'.
5. Adjust the reading on the disc to zero against pointer. Also, set the dial pointer to zero.
6. Rotate the hand wheel and apply the torque. Take the value of torque for each 1° of angle of twist upto 6° such that the material is still in elastic limit.
7. A graph is drawn between torque 'T' (y-axis) and angle of twist 'θ' (x-axis) and calculate the slope of the straight line.
8. Calculate the Modulus of rigidity of the material from graph.

OBSERVATIONS

Least count of vernier calipers = 0.002 cm

Length of the specimen 'L' = cm

Measurement of the diameter of the specimen

| S. No. | Main scale reading M.S.R (cm) | Vernier Scale coincidence V.S.C (div) | Diameter = M.S.R + L.C x V.S.C (cm) |
|--------|----------------------------------|---|--|
| 1 | | | |
| 2 | | | |
| 3 | | | |

Average diameter of the specimen 'd' = cm

| S. No. | Angle of twist | | Torque or twisting moment (kg-cm) |
|--------|----------------|-----------|--------------------------------------|
| | (Degrees) | (Radians) | |
| 1 | | | |

| | | | |
|---|--|--|--|
| 2 | | | |
| 3 | | | |
| | | | |
| | | | |

CALCULATIONS:

Polar Moment of Inertia 'J' = $\pi d^4 / 32.$ = cm^4

Specimen Calculation:

T = $\text{kg - cm};$

θ = radians

$$G = \frac{TL}{\theta J}$$

The rigidity modulus (G) of the given material from the graph

$$= \frac{TL}{\theta J} = \text{kg / cm}$$

RESULT:

The rigidity modulus (G) of the given material from the graph = kg / cm^2

EXPERIMENT 8

BENDING TEST ON A SIMPLY SUPPORTED BEAM

AIM: To Determine the Young's Modulus of the material of the simply supported beam.

EQUIPMENT:

Simply supported beam, hanger with weights, dial gauge, vernier calipers and metre scale.

PRINCIPLE / THEORY:

Young's modulus: The ratio of stress to strain within the proportionality limit.

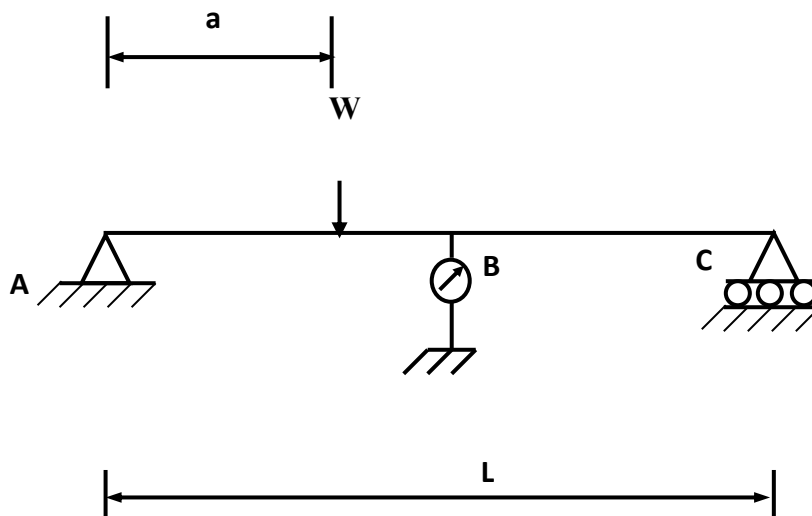

Fig. 1

- | | | |
|---|---|--|
| A | - | Left support |
| C | - | Right support |
| B | - | Mid span ($AB = BC$) |
| L | - | Span (AC) |
| W | - | Load applied |
| a | - | The distance of the load from the left support |

The formula for deflection ‘ δ ’ under the dial gauge ‘B’

$$\delta = \frac{Wa(3L^2 - 4a^2)}{48EI}$$

PROCEDURE:

1. Measure the dimensions of the beam i.e. the length ‘L’, between the centers of supports, width ‘b’ and depth ‘d’.
2. Fix the dial gauge at the center of the beam for measuring deflection such that the needle of the dial gauge touches the bottom of the beam.
3. Place the hanger at a measured distance ‘L₁’ from the fixed support, record the reading on the dial gauge. Successively place the additional weights on the hanger. Record the readings of the dial gauge when each weight is added and also during unloading.
4. Plot a graph with load along y-axis and deflection along x-axis and obtain best-fitted straight line. Calculate the slope of the straight line.
5. Calculate the Young’s modulus ‘E’ of the material.
- 6.

OBSERVATIONS:

Least Count of Dial Gauge = 0.001cm

Least Count of Vernier calipers = 0.002 cm

Width of beam ‘b’:

| S. No. | Main scale reading M.S.R. (cm) | Vernier scale coincidence V.S.C. (div) | Width = M.S.R. + L.C. x V.S.C (cm) |
|--------|--------------------------------|--|------------------------------------|
| 1 | | | |
| 2 | | | |
| 3 | | | |

Average width in cm =

Depth of Beam ‘d’:

| S. No. | Main scale reading M.S.R. (cm) | Vernier scale coincidence V.S.C. (div) | Width = M.S.R. + L.C. x V.S.C (cm) |
|--------|--------------------------------|--|------------------------------------|
| 1 | | | |
| 2 | | | |
| 3 | | | |

Average depth in cm =

| S. No. | Load applied (kg) | Dial gauge Reading | | | Deflection = Av. x L. C. (cm) |
|--------|-------------------|----------------------|------------------------|-----------------------|-------------------------------|
| | | During Loading (div) | During unloading (div) | Average Reading (div) | |
| 1 | | | | | |
| 2 | | | | | |
| 3 | | | | | |
| 4 | | | | | |
| 5 | | | | | |
| 6 | | | | | |
| 7 | | | | | |
| 8 | | | | | |

CALCULATIONS:

Moment of inertia of the cross section of the beam, $I = bd^3 / 12 =$ cm⁴

Specimen Calculation:

W = Kgs. $\delta =$ cm.

$$\text{Young's Modulus } E = \frac{Wa(3L^2 - 4a^2)}{48 \delta I} = \text{kg/cm}^2$$

$$\text{Young's Modulus from graph 'E'} = \frac{W}{\delta} \left(\frac{a(3L^2 - 4a^2)}{48 I} \right)$$

RESULT:

Young's Modulus 'E' of the material of the simply supported beam =
Kg/cm²

EXPERIMENT 9

BENDING TEST ON A CANTILEVER BEAM

AIM: To Determine the Young's Modulus of the material of cantilever beam.

EQUIPMENT:

Cantilever beam, Hanger with weights, Dial gauge, Vernier calipers and Metre scale.

PRINCIPLE / THEORY:

Young's modulus: The ratio of stress to strain within the proportionality limit.

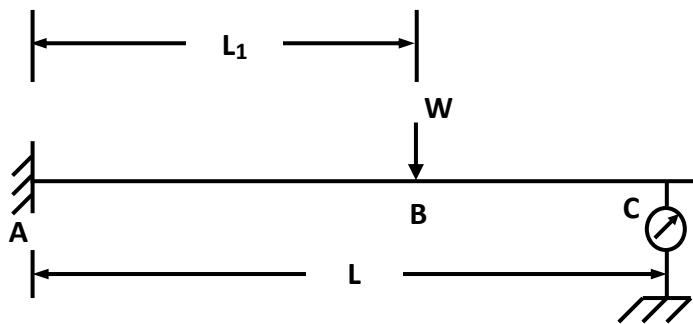

Fig. 1

- A - Fixed support
- C - The point where dial gauge is fixed
- L - Distance of point 'C' from fixed end.
- W - Load applied
- L₁ - The distance of the load from the fixed support

The formula for deflection 'δ' under the dial gauge 'C'

$$\delta = \frac{WL_1^3}{3EI} + \frac{WL_1^2(L - L_1)}{2EI}$$

PROCEDURE:

1. Measure the cross sectional dimensions of the beam i.e., width 'b' and depth 'd'.
2. Fix the dial gauge near the free end of the beam for measuring deflection with the needle just touching the bottom of the beam.
3. Measure the distance 'L' between the face of the fixed support and the dial gauge.
4. Place the hanger at a measured distance 'L₁' from the fixed support, record the reading on the dial gauge. Successively place the additional weights on the hanger. Record the readings of the dial gauge when each weight is added and also during unloading.
5. Plot a graph with load along y-axis and deflection along x-axis and obtain best-fitted straight line. Calculate the slope of the straight line.
6. Calculate the Young's modulus 'E' of the material.

OBSERVATIONS:

Least Count of Dial Gauge =

Least Count of Vernier calipers =

Width of beam 'b':

Depth of Beam 'd':

| S. No. | Main scale reading M.S.R. (cm) | Vernier scale coincidence V.S.C. (div) | Width = M.S.R. + L.C. x V.S.C (cm) |
|--------|--------------------------------|--|------------------------------------|
| 1 | | | |
| 2 | | | |
| 3 | | | |

Average width in cm =

| S. No. | Main scale reading M.S.R. (cm) | Vernier scale coincidence V.S.C. (div) | Width = M.S.R. + L.C. x V.S.C (cm) |
|--------|--------------------------------|--|------------------------------------|
| 1 | | | |
| 2 | | | |
| 3 | | | |

Average depth in cm =

| S. No. | Load applied (kg) | Dial gauge Reading | | | Deflection = Av. x L. C. (cm) |
|--------|-------------------|----------------------|------------------------|-----------------------|-------------------------------|
| | | During Loading (div) | During unloading (div) | Average Reading (div) | |
| 1 | | | | | |
| 2 | | | | | |
| 3 | | | | | |
| 4 | | | | | |
| 5 | | | | | |
| 6 | | | | | |

CALCULATIONS:

Moment of inertia of the cross section of the beam, $I = bd^3 / 12 = \text{cm}^4$

Specimen Calculation:

$W = \text{kg}$, $\delta = \text{cm}$.

$$\text{Young's Modulus 'E'} = \frac{WL_1^3}{3\delta I} + \frac{WL_1^2(L-L_1)}{2\delta I}$$

$$= \text{kg/cm}^2$$

$$\text{Young's Modulus from graph 'E'} = \frac{W}{\delta} \left(\frac{L_1^3}{3I} + \frac{L_1^2(L-L_1)}{2I} \right)$$

RESULT: Young's Modulus 'E' of the material of the cantilever beam

from graph = kg/cm²

INFERENCE:

EXPERIMENT 10

BENDING TEST ON A FIXED BEAM

AIM: To Determine the Young's Modulus of the material of the fixed beam.

EQUIPMENT:

Fixed beam, hanger with weights, dial gauge, venire calipers and metre scale.

PRINCIPLE / THEORY:

Young's modulus: The ratio of stress to strain within the proportionality limit.

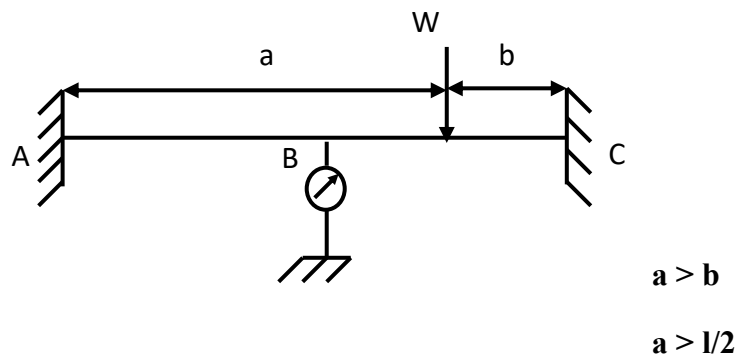

- A - Left support
- C - Right support
- B - Mid span (AB = BC)
- L - Span (AC)
- W - Load applied
- a - The distance of the load from the left support

The formula for deflection 'δ' under the dial gauge 'B'

$$\delta = \frac{Wb^2(3a - b)}{48EI}$$

PROCEDURE:

1. Measure the dimensions of the beam i.e. the length 'L', between the centers of supports, width 'b' and depth 'd'.
2. Fix the dial gauge at the center of the beam for measuring deflection such that the needle of the dial gauge touches the bottom of the beam.
3. Place the hanger at a measured distance 'a' from the left fixed support, record the reading on the dial gauge. Successively place the additional weights on the hanger. Record the readings of the dial gauge when each weight is added and also during unloading.
4. Plot a graph with load along y-axis and deflection along x-axis and obtain best-fitted straight line. Calculate the slope of the straight line.
5. Calculate the Young's modulus 'E' of the material.

OBSERVATIONS:

Least Count of Dial Gauge = 0.001cm

Least Count of Vernier calipers = 0.002 cm

Width of beam 'b':

| S. No. | Main scale reading M.S.R. (cm) | Vernier scale coincidence V.S.C. (div) | Width = M.S.R. + L.C. x V.S.C (cm) |
|--------|--------------------------------|--|------------------------------------|
| 1 | | | |
| 2 | | | |
| 3 | | | |

Average width in cm =

Depth of Beam 'd':

| S. No. | Main scale reading M.S.R. (cm) | Vernier scale coincidence V.S.C. (div) | Width = M.S.R. + L.C. x V.S.C (cm) |
|--------|--------------------------------|--|------------------------------------|
| 1 | | | |
| 2 | | | |
| 3 | | | |

Average depth in cm =

| S. No. | Load applied (kg) | Dial gauge Reading | | | Deflection = Av. x L. C. (cm) |
|--------|-------------------|----------------------|------------------------|-----------------------|-------------------------------|
| | | During Loading (div) | During unloading (div) | Average Reading (div) | |
| 1 | | | | | |
| 2 | | | | | |
| 3 | | | | | |
| 4 | | | | | |
| 5 | | | | | |
| 6 | | | | | |

CALCULATIONS:

Moment of inertia of the cross section of the beam, $I = bd^3 / 12 = \quad \text{cm}^4$

Specimen Calculation:

$W = \quad \text{Kgs.}, \quad \delta = \quad \text{cm.}$

$$\text{Young's Modulus } E = \frac{Wb^2(3a - b)}{48\delta I}$$

$= \quad \text{kg/cm}^2$

$$\text{Young's Modulus } E \text{ from graph} = \frac{W}{\delta} \left(\frac{b^2(3a - b)}{48 I} \right)$$

RESULT:

Young's Modulus 'E' of the material of the fixed beam From graph = $\quad \text{kg/cm}^2$